

PERFORMANCE ASSESSMENT OF WOOD STRAND EROSION CONTROL MATERIALS AMONG VARYING SLOPES, SOIL TEXTURES AND COVER AMOUNTS

Kristina Anne Yanosek¹, Randy Bruce Foltz², James Henry Dooley³

¹Civil Engineer, Rocky Mountain Research Station, USDA Forest Service, 1221 South Main Street, Moscow, ID 83843; phone: (208) 883-2309; fax: (208) 883-2318; email: kyanosek@fs.fed.us.

²Research Engineer, Rocky Mountain Research Station, USDA Forest Service, 1221 South Main Street, Moscow, ID 83843; phone: (208) 883-2312; fax: (208) 883-2318; email: rfoltz@fs.fed.us.

³President, Forest Concepts, LLC, 1911 SW Campus Drive #655, Federal Way, Washington 98023; phone: (253) 838-4759; fax: (253) 815-9900; email: jdooley@seanet.com.

ABSTRACT. Two blends of manufactured wood strands with different lengths were tested for effectiveness in controlling erosion. Wood strand blends were tested on two soils, two slope steepnesses, and at three coverage amounts. Laboratory rainfall simulations were conducted to evaluate runoff and sediment loss. Wood strands were effective in delaying runoff, reducing runoff volume, and reducing sediment loss. There was no statistically significant difference between the two wood strand blends with respect to runoff or sediment loss. In comparison to bare soil with no cover, sediment loss was reduced by at least 70 percent for all cover amounts tested and among each soil type, slope and flow event. In comparison to estimates of sediment loss reductions due to agricultural straw (Burroughs and King, 1989), wood strand materials were equally effective on coarse grained soils and superior to straw on fine grained soils. In contrast to agricultural straw, manufactured wood strands are inherently weed and pesticide free. Consequently, wood-based materials may be a more appropriate material for erosion mitigation, especially in areas where introduction of non-native species is of great concern.

Keywords. Mitigation, runoff, soil erosion control, straw mulch, water quality.

Agricultural straw, hydromulch, and other natural and man-made materials are commonly used as ground cover for soil erosion mitigation. Such materials are utilized on soils disturbed by fire, timber harvesting, road building, and other areas at risk of rainfall-induced soil erosion. Agricultural straw is widely used because it is usually inexpensive, readily available and more effective than many other erosion control products (Robichaud et al., 2000). Alternatives for erosion control products are more limited in forests than in urban applications due to project scale and constraints on application methods and cost. While agricultural straw is highly

effective in reducing erosion, it is non-native to forested areas and may disrupt the natural habitat by introducing non-native vegetation (Robichaud et al., 2000). Kruse et al. (2004) found that non-native species were more prevalent on burned areas treated with certified weed-free straw mulch than those left untreated on the Six Rivers National Forest in California.

An optimal erosion control material for forests would be derived from natural materials native to the watershed in which they are applied. Natural erosion control after low and moderate severity wildfires is provided by needle cast which fall within weeks after the fire (Pannkuk and Robichaud, 2003). Needle cast is commercially marketed as “pine straw” in the southeastern United States; however, no commercial sources of pine straw have been identified in the Western United States. Wood-based materials such as hydraulically applied mulches, wood chips, and the wood strands discussed in this report may provide ecologically preferable erosion control alternatives.

In a previous study, Foltz and Dooley (2003) determined that manufactured wood strands, specifically designed for erosion control, were functionally equivalent to straw with respect to runoff and sediment reduction when applied at 70 percent cover. Foltz and Dooley used strand lengths of 60, 120 and 240 mm (2.4, 4.7, and 9.4 in). The study concluded that 240 mm (9.4 in) strands were longer than needed to encourage material interweaving. The extra length made handling unnecessarily more difficult and limited application methods. It was also determined that 60 mm (2.4 in) strands were not mobile in the runoff which was a concern given that shorter material pieces such as wood chips tend to float away in overland flow. These results established a starting point for wood strand length and blend optimization. The objectives of the present study were to further evaluate wood strand lengths and cover application rates, and determine their erosion control potential under different slope, soil and coverage conditions.

METHODS AND MATERIALS

Laboratory research was conducted at the USDA Forest Service, Rocky Mountain Research Station in Moscow, Idaho from March 2003 through April 2004. Rainfall simulations were conducted on indoor soil plots covered with wood strands. Treatments included two wood strand length blends, two soil types (gravelly sand and sandy loam), two slopes (15 and 30 percent), and four soil cover levels (0, 30, 50, and 70 percent). There were four replicates for each treatment, resulting in an incomplete factorial with 112 combinations. All 56 treatments on gravelly sand were completed first and followed by 56 treatments on sandy loam.

The wood strand material used for this research was produced by Forest Concepts, LLC, Federal Way, Washington. Wood strands were sliced from post-industrial Douglas fir wood waste veneer acquired from local mills in western Washington. The resulting strands were 3 mm (0.125 in) thick by 6 mm (0.24 in) wide (Figure 1).



Figure 1. Wood strand material.

The design of a two-component blend of wood strands is based in part upon research by Pannkuk and Robichaud (2003) related to erosion control efficacy of conifer needles. The study concluded that short Douglas fir needles, measuring approximately 26 mm (1 in), more effectively controlled interrill erosion due to their high ground contact. Ponderosa pine needles, measuring 165 mm (6.5 in), were more effective in reducing development of rills due to their ability to knit into mini-debris dams. Another study by Buchanan et al. (2000) concluded that small wood chips were highly mobile on road embankments demonstrating that cover materials should be designed such that pieces interweave to promote stability on slopes.

Strands for this study were manufactured to 40, 80 and 160 mm (1.6, 3.1, and 6.3 in) lengths. Two wood strand blends were made from pure lots of these three component-lengths, one with long and short strands, referred to as the 160-40 blend and one with long and medium strands, referred to as the 160-80 blend. Materials were combined by equal masses of the two desired lengths resulting in approximate piece ratios of 1:2 for the 160-80 blend and 1:4 for the 160-40 blend.

A coarse grain soil and a fine grain soil were selected to represent the range of textures found on forestlands in the western United States. The coarse grain soil had a gravelly sand (GS) texture of 30 percent gravel and non-rock measures of 88 percent sand, 10 percent silt, and 2 percent clay. The fine grain soil was a sandy loam with 58 percent sand 37 percent silt, and 5 percent clay. Both soils were sieved through a 6-mm mesh screen to remove large diameter particles and organic material. The mean diameter of the gravelly sand and sandy loam soils were 0.93 and 0.08 mm, respectively.

After being dried to hygroscopic water content (approximately 0.45 percent moisture for gravelly sand and 7.3 percent for sandy loam), the soil was mixed and placed in a frame measuring 1.24 m (4 ft) wide, 4 m (13 ft) long and 0.20 m (0.7 ft) deep. The plot area was 4.96 m² (53 ft²). Slots in the frame bottom and a geotextile fabric (Phillips 6-WS) provided a path for infiltrated water to flow through the soil profile and out of the plot. The soil surface was screed in the shape of a trapezoid with a center width of 80 mm (3 in) and side slopes of 5 percent (Figure 2). The purpose of the cross-slope was to direct water away from the sides of the plot frame to avoid plot edge effects. The average bulk densities of the gravelly sand and sandy loam were 1.71 g cm⁻³ (106.7 lb ft⁻³) and 1.35 g cm⁻³ (84.3 lb ft⁻³), respectively.

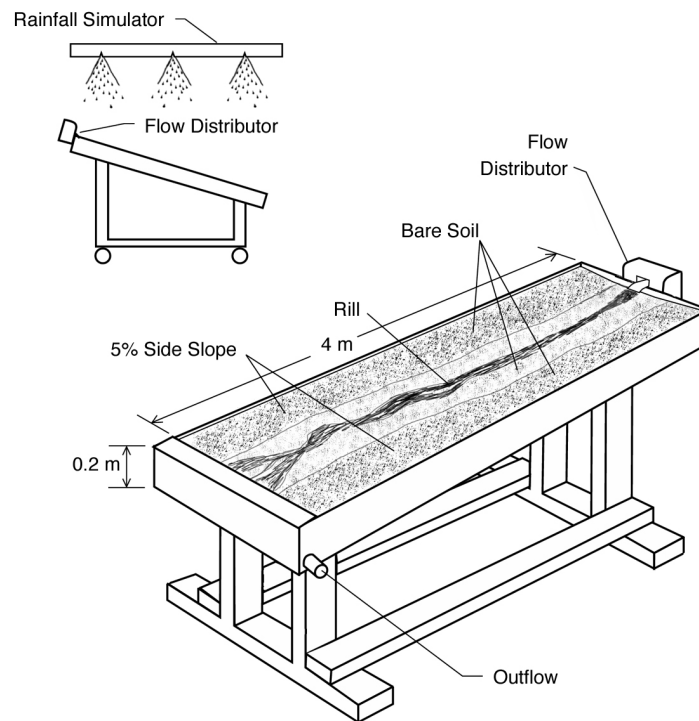

Figure 2. Sketch of plot layout.

Wood strand cover was applied by hand casting from a platform approximately 1.5 m (4.9 ft) above the sloping plot. Application rates were estimated based on material mass per unit area to achieve a desired ground cover. Measurements of wood strand coverage were taken using a point-intercept grid on a clear acrylic sheet with a total of 1089 points spaced 25 mm (1 in) apart. Cover points were counted using 605 of the 1089 points at three locations (upper, middle and lower section) of the plot and combined for a plot-level average. In cases where the measured cover was more than five percentage points from the target cover, the cover amount was adjusted and re-counted.

Gravimetric soil moisture content was measured before and after each rainfall simulation by oven-drying soil samples overnight at 105°C (221°F). Bulk density was determined before and after rainfall simulation for selected plots using a Troxler Model 3440 nuclear gauge. Both soil moisture and bulk density measurements were taken at three locations along the length of the plot.

On selected plots, pre- and post-rainfall wood strand moisture was determined. Wood strands were oven dried overnight at 105°C (221°F) to determine the amount of water absorbed during rainfall simulations and distinguish between infiltration and matrix storage.

A Purdue type rainfall simulator (Foster et al., 1982) equipped with VeeJet 80150 nozzles and operated at 41 kPa (6 psi), which deliver a raindrop size distribution approximating natural rainfall (Meyer and Harmon, 1979). The rainfall rate used in this study was 50 mm hr⁻¹ (2 in hr⁻¹). A storm at this intensity and with a 15-minute duration has a 50-year return period in the Intermountain West based on NOAA Atlas 2 (NOAA, 1973).

Overland flow was applied via a flow dispersal manifold at the top of the plot across the flat 80-mm width of the trapezoidal surface. After 15 minutes of rainfall, the first flow (1 L min⁻¹) was added. This flow rate was chosen based on the critical shear required to detach the mean particle diameter size of the gravelly sand soil on a 30-percent slope (Elliot et al., 1989). Five minutes later, the flow rate was increased to 4 L min⁻¹ (two times the critical shear) and continued for five minutes after which both flow and rainfall were simultaneously stopped. Added flow rates were not adjusted to meet the critical shear of the sandy loam soil or the 15 percent slope plots in order to maintain identical rain and flow conditions for all soil and slope combinations. Throughout this report, the three rainfall/inflow rates are referred to as the “rainfall only” (R), “rainfall plus 1-L flow” (R+1) and “rainfall plus 4-L flow” (R+4) events.

Timed grab samples taken each minute were used to determine runoff rates and sediment concentrations. Sediment concentrations were determined by oven-drying the grab samples for 24 hours at 105°C (221° F). Presence (or absence) of rills was recorded following each rainfall simulation.

To assess consistency of initial plot conditions, separate general linear models were used to test for differences in bulk density, soil moisture, and differences between measured and target cover amounts. To determine effects of wood strands under varying conditions, all treatments (soil type, slope, strand blend type, and cover amount) were tested using a general linear model (SAS, 2003). Both runoff volume and sediment yield from the R, R+1, and R+4 flow events were analyzed in this manner. When treatments were significantly different, least square means were compared using a t-test.

RESULTS AND DISCUSSION

Initial plot conditions were sufficiently consistent to enable isolation of treatment effects. No significant differences (at p=0.05) in soil bulk density or initial

soil moisture content were observed among all experiments for either soil type. The only statistically significant differences between measured and target cover amounts (Table 1) were the 70 percent target cover on gravelly sand (67 percent observed) and the 50 percent target cover on sandy loam (52 percent observed). In subsequent analysis, nominal classification names of 0, 30, 50, and 70 percent were used. For analysis where continuous variables were appropriate, observed averages were used.

Table 1. Average observed cover amounts among mixes for each target cover.

Soil Type	Average Observed Wood Strand Cover (%)		
	Target = 30%	Target = 50%	Target = 70%
GS	30 ± 1.3*	50 ± 2.2*	67 ± 2.9 [†]
SL	30 ± 1.7*	52 ± 2.1 [‡]	69 ± 1.9*

GS=Gravelly sand soil.

SL=Sandy loam soil.

*p-value > 0.05.

[†]p-value=0.0043.

[‡]p-value = 0.0003.

The relationship between application rate and wood strand cover had a coefficient of determination r^2 of 0.977 (p-value of < 0.0001):

$$C = 61.3 \times W^{0.78}$$

where C is the cover in percent and W is the application rate in kg m^{-2} . Based on Burroughs and King (1989), application rates for agricultural straw for 30, 50 and 70 percent ground cover were estimated as 0.02, 0.11, and 0.30 kg m^{-2} (0.10, 0.48, and 1.34 t ac^{-2}). More than four times as much mass would be required to achieve these cover amounts with the wood straw used in this study (Table 2). Straw application rates used in practice, however, typically range between 0.22 and 0.45 kg m^{-2} (1 to 2 ton ac^{-2}) (Robichaud et al., 2000). Based on the results of this study (described in following text), optimal wood straw cover would be near 50 percent cover with a corresponding application rate of 0.77 kg m^{-2} (3.44 t ac^{-1}).

Table 2. Wood strand cover and corresponding application rates.

Wood Strand Cover (%)	Wood Strand Application Rate	
	(kg m^{-2})	(t ac^{-1})
30	0.40	1.78
50	0.77	3.44
70	1.19	5.29

Time to runoff was delayed as wood strand cover was increased as shown in representative hydrographs (Figure 3). Runoff from bare plots began between 5 to 6 minutes after the start of rainfall and approached steady state near the end of the R flow period. In comparison, none of the plots with wood strand cover were

approaching steady state at the end of the R flow period. Water was observed flowing around individual wood strands, rather than downslope, thus increasing flow path length. Increased flow path length decreased velocity and increased infiltration opportunity. On plots with 70 percent cover, runoff was delayed by 7-8 minutes on GS soils and by 11-12 minutes on SL soils in comparison to bare plots with no cover. Most runoff occurring on plots with 70 percent cover was due to the concentrated added flow.

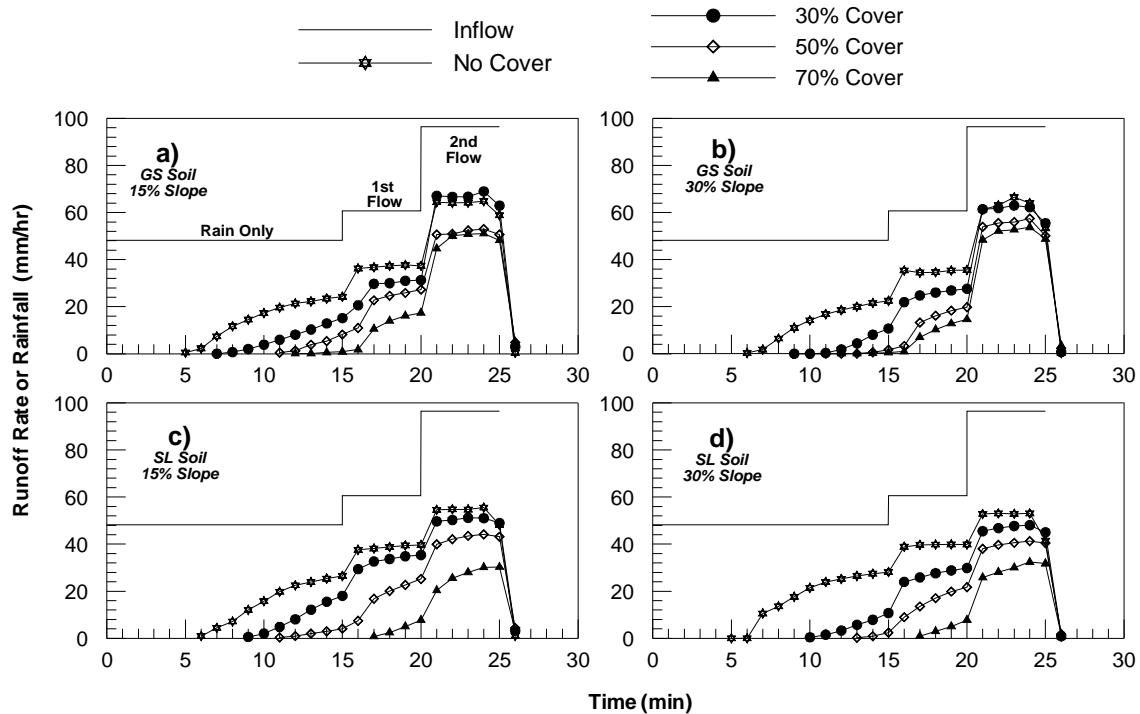

Figure 3. Hydrographs for rainfall simulations on gravelly sand and sandy loam soils on 15 and 30 percent slopes. Results shown are those from simulations with 160-40 wood strand blend with each line representing the average response from four replicates.

Rill formation was the predominate erosion mechanism on the gravelly sand soil occurring on 7 of the 8 bare plots. Increasing amounts of cover reduced the incidence of rilling on gravelly sand plots. Rills occurred on 10 of 16 plots with 30 percent cover; 6 of 16 plots with 50 percent cover; and 5 of 16 plots with 70 percent cover. On bare plots, rill formation was more extensive than on plots with wood strands which slowed rill formation by forming mini-debris dams. It was observed that wood strands dispersed water over the plot resulting in slower, less erosive flows. The resulting slower flows reduced shear forces thus reducing the extent of rilling, and soil particle detachment and transport.

The predominant form of erosion on sandy loam soils was sheet erosion as evidenced by low incidences of rilling. None of the sandy loam plots with wood strand cover had rills and only one of the bare plots had rills. The primary sediment

reduction mechanism of wood strands on sandy loam soil was raindrop splash reduction .

Soil, slope and wood strand cover amount were all significant ($p < 0.05$) with respect to both runoff and sediment loss at the R+4 flow (Table 3). Wood strand cover amount was the only source of significantly different ($p < 0.0001$) runoff sediment loss at all three flow levels. No significant differences were seen between 160-80 and 160-40 wood strand blends. Both runoff and sediment loss were significantly greater (at $p = 0.05$) on gravelly sand than on the sandy loam (Tables 4 and 5). Differences in sediment loss and runoff among soils existed only from added flows applied after 15 minutes of rainfall (R+1 and R+4 events) which was due to extensive rilling on gravelly sand soils. Runoff and sediment loss were also significantly different among the two slopes for R+1 and R+4 events. Although sediment loss was greater on 30 percent slopes (Table 5), runoff was slightly greater on 15% slopes (Table 4) during R+4. Higher runoff on the lesser slope was likely due to greater surface sealing caused by slower moving flows. Increased wood strand cover amounts resulted in significant decreases in runoff (Table 4) and sediment loss (Table 5) for all three flow events. Significant differences existed among all contrasts except for that between 50 and 70 percent cover during the R flow event.

Table 3. General linear model statistical analysis of runoff and sediment loss.

Source (df*)	P-value for runoff from three rainfall/flow events		
	R	R+1	R+4
Soil (1)	0.6070	0.8796	<0.0001
Slope (1)	0.3669	0.0958	0.0457
Wood Strand Cover (3)	<0.0001	<0.0001	<0.0001
Source (df*)	P-value for sediment loss from three rainfall/flow events		
	R	R+1	R+4
Soil (1)	0.4657	0.0010	<0.0001
Slope (1)	0.2879	0.0005	<0.0001
Wood Strand Cover (3)	<0.0001	<0.0001	<0.0001

*Degrees of freedom.

R = Rainfall only.

R+1 = Rainfall plus 1 L/s overland flow.

R+4 = Rainfall plus 4 L/s overland flow.

Two interactions between soil cover and soil slope resulted in significantly different runoff and sediment loss (Table 6). Effectiveness of wood strand cover was dependent on soil texture for both concentrated flows (R+1 and R+4). There was a greater reduction in sediment from the sandy loam soil when increasing the cover from 50 to 70% (Figure 4) suggesting that finer grained soils may benefit more by increasing ground cover beyond 50 percent. Increases in sediment due to increases in slope were greater for the gravelly sand soil implying wood strands were more effective on finer grained soils on steeper slopes (Figure 4).

Table 4. Statistically significant least squares means of runoff.

Treatment	Treatment Level	Least square means of runoff (L) for each rainfall/inflow rate		
		R	R+1	R+4
Soil	GS	NS	NS	38
	SL			31
Slope	15%	NS	NS	36
	30%			33.
Cover	0%	12	27	53
	30%	3.0	14	38
	50%	0.43	6.6	28
	70%	0.06	2.5	20

GS=Gravelly sand.

SL=Sandy loam.

NS=Not Significant.

R = Rainfall only.

R+1 = Rainfall plus 1 L/s overland flow.

R+4 = Rainfall plus 4 L/s overland flow.

Table 5. Statistically significant least squares means of sediment loss.

Treatment	Treatment Level	Least square means of sediment loss (g) for each rainfall/inflow rate		
		R	R+1	R+4
Soil	GS	NS	130	930
	SL		82	380
Slope	15%	NS	81	330
	30%		130	1060
Cover	0%	450	1070	2980
	30%	23	190	760
	50%	0.94	55	300
	70%	NE	10	190

GS=Gravelly sand.

SL=Sandy loam.

NS=Not significant.

NE=Unable to estimate.

R=Rainfall only.

R+1=Rainfall plus 1 L/s overland flow.

R+4=Rainfall plus 4 L/s overland flow.

Retention of rainfall by wood strands was a minor factor in runoff reduction. Average water retention by wood strands was 1.3, 2.8, and 4.3 percent of the total rainfall on respective 30, 50 and 70 percent cover plots for the 25-minute rainfall

simulations. Water retention within the wood strand cover was attributed to a combination of adsorption on the surface of individual strands, absorption by the wood, and matrix storage associated with the points of contact between overlapping strands.

Table 6. General linear model statistical analysis of runoff and sediment loss for two-way interactions.

Interaction Source (df*)	P-value for runoff		
	R	R+1	R+4
Soil Slope (3)	0.0488	0.0673	0.0928
Soil Cover (3)	0.1335	0.0292	0.0014
Interaction Source (df*)	P-value for sediment		
	R	R+1	R+4
Soil Slope (3)	0.4384	0.4657	<0.0001
Soil Cover (3)	0.4657	<0.0001	0.0005

*Degrees of freedom

R = Rainfall only.

R+1 = Rainfall plus 1 L/s overland flow.

R+4 = Rainfall plus 4 L/s overland flow.

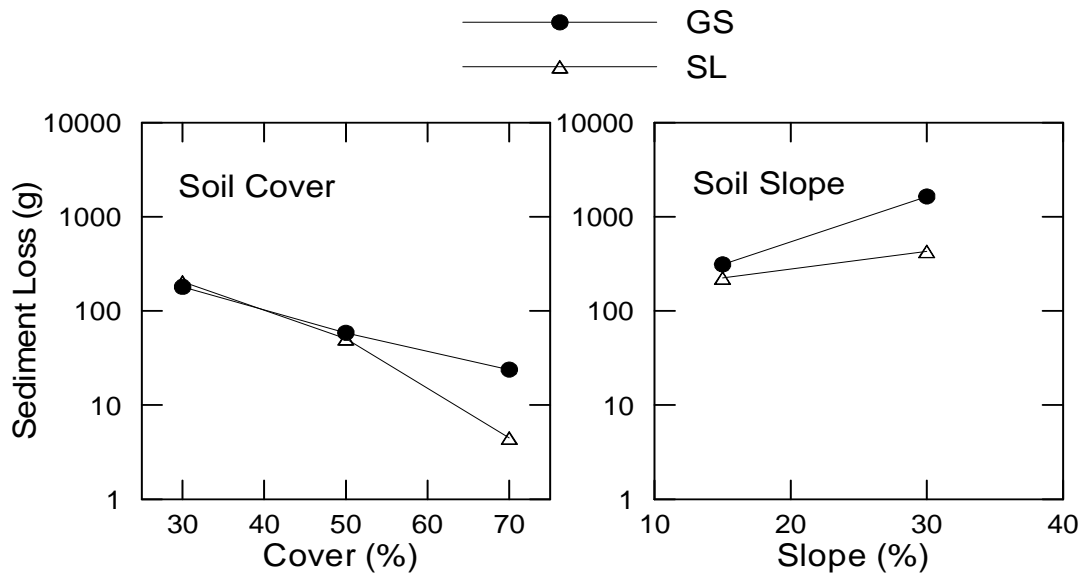

Figure 4. Soil cover interaction for R+1 and soil slope interaction for R+4.

All levels of wood strand cover were shown to be beneficial for runoff and sediment reduction when compared to bare plots (Figures 5 and 6). For a small storm (as represented by the R flow) on gravelly sand, runoff was reduced by 80, 95, and 98 percent with 30, 50 and 70 percent wood strand cover, respectively (Figure 5). As more concentrated flow was added, effectiveness of wood strand cover decreased. Sediment reduction from increased cover levels was less distinct

between different flows (Figure 6). Sediment loss was reduced by at least 70 percent for all cover levels.

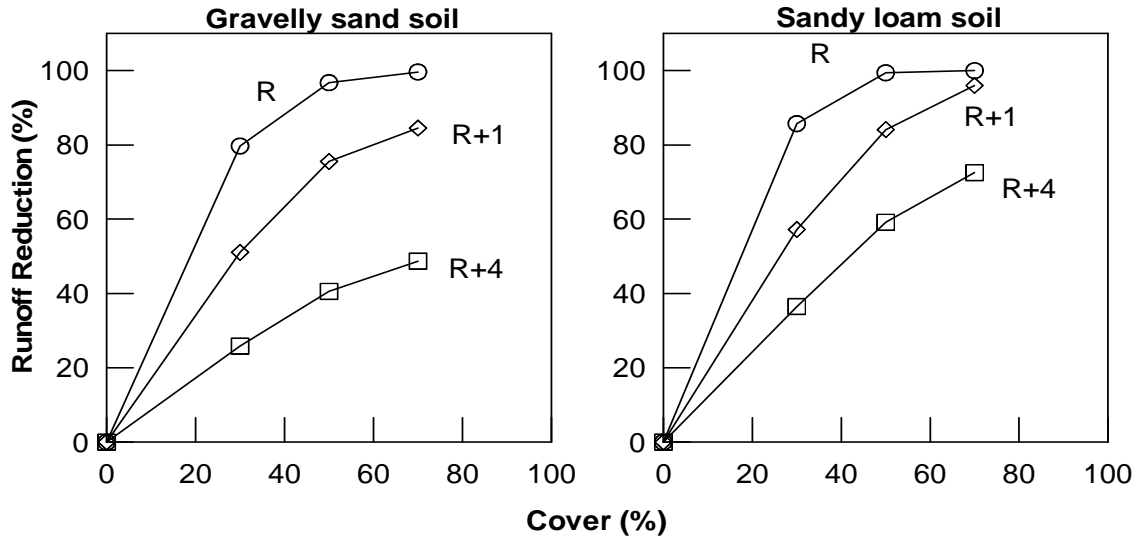

Figure 5. Runoff reduction as a percentage of that from bare plots on 30 percent slopes.

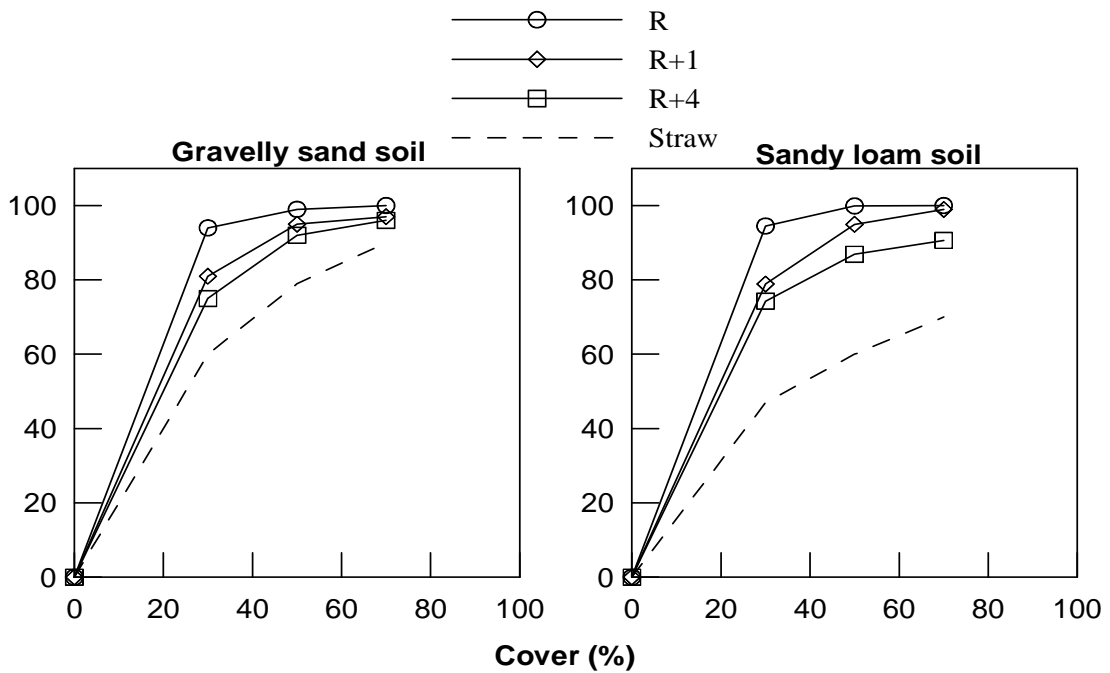

Figure 6. Sediment reduction with respect to bare plots (this study) and agricultural straw (estimated using Burroughs and King, (1989)).

Reduction in sediment loss due to agricultural straw was estimated based on Burroughs and King (1989) for comparison to wood strands (Figure 6). On the gravelly sand soil, agricultural straw and wood strands are similar with respect to sediment loss. On the sandy loam soil, sediment reduction from the wood strands was higher than straw.

A distinguishing difference between agricultural straw and wood strands is the three-dimensional layering effect of wood strands. The stability of the matrix formed by wood strands was an important factor in reducing erosion and preventing propagation of rills. Wood strands on plots with 30 percent cover typically formed a single layer with most pieces having complete contact with the soil surface. On plots with 50 and 70 percent cover, there were multiple layers of wood strands. At 50 percent cover, wood strands appeared to form two to three layers while 70 percent cover resulted in approximately three to four layers of strands.

SUMMARY AND CONCLUSIONS

Engineered wood strands were effective for erosion control by delaying initiation of runoff, reducing the volume of runoff, and reducing sediment loss. Significant decreases in runoff and sediment loss occurred for increasing amounts of wood strand cover. There were no statistically significant differences between the two wood strand blends with respect to either volume of runoff or sediment loss. Retention of rainfall by wood strands was a minor factor in reducing runoff.

The reduction of runoff volume due to wood strands was higher on the finer grained sandy loam than the coarser grained gravelly sand. Wood strands decreased runoff by 80 to 99 percent during the simulated low-intensity storm (R). For the high-intensity storm (R+4), wood strands were not as effective at the lower cover levels. Thirty percent cover reduced runoff by 25 to 35 percent while 70 percent cover reduced runoff by 45 to 70 percent.

Sediment loss was greater from plots with wood strands on coarse grained soil than from fine grained soil. For the high-intensity storm, sediment was reduced by 76, 93, and 96 percent for 30, 50 and 70 percent covers, respectively on the gravelly sand soil. On the sandy loam soil, sediment was reduced by 70, 85, and 90 percent for 30, 50, and 70 percent cover, respectively. In comparison to estimated sediment reduction by agricultural straw, wood strands were more effective, particularly for the finer grained sandy loam soil.

The use of wood strands as a substitute for agricultural straw may reduce the frequency of invasive species introduction. Long-term effects of wood strand erosion control materials on revegetation have not yet been determined. Reducing the thickness of wood strands can reduce the mass per unit area, and hence the cost of application, without reducing the percent ground cover. Additional studies using these thinner strands is warranted in order to reduce the application rates required to achieve the desired cover. Material thickness may also be optimized towards decomposition rates most advantageous for revegetation success. Tests

are currently ongoing to determine the effectiveness of wood strand materials under field conditions.

ACKNOWLEDGEMENTS

The authors acknowledge the work of Ben Kopyscianski (Rocky Mountain Research Station), who prepared all the plots and maintained the rainfall simulation equipment and Justin Maschhoff (Forest Concepts), who made all the wood strands for the study. The project was supported by the Small Business Innovation Research program of the U.S. Department of Agriculture, grant #2004-33610-14424.

REFERENCES CITED

- Buchanan, John R., Daniel C. Yoder, and James L. Smoot. 2000. Controlling soil erosion on construction sites with steep slopes with wood chips. ASAE Paper 002060. Presented at the 2000 ASAE Annual International Meeting. St. Joseph, MI: ASAE.
- Burroughs and King. 1989. Reduction of soil erosion on forest roads. USDA Forest Service, General Technical Report 264. Ogden, UT: USDA Forest Service
- Elliot, W. J., A. M. Libenow, J. M. Laflen, and K. D. Kohl. 1989. A compendium of soil erodibility data from WEPP cropland soil field erodibility experiments, 1987 and 1988. NSERL Report 3. Columbus, Ohio: Ohio State University and USDA Agricultural Research Service.
- Foltz, R.B. and J.H. Dooley. 2003. Comparison of erosion reduction between wood strands and agricultural straw. *Trans. ASAE* 46(5): 1389-1396.
- Foster, G.R., W.H. Neibling, and R.A. Nattermann. 1982. A programmable rainfall simulator. ASAE Paper No. 822570. Presented at the 1982 ASAE Winter Meeting. St. Joseph, Mich.: ASAE.
- Kruse, R., E. Bend, and P. Bierzychudek. 2004. Native plant regeneration and introduction of non-natives following post-fire rehabilitation with straw mulch and barley seeding. *Forest Ecology and Management* 196(2-3): 299-310.
- Meyer, L.D., and W.C. Harmon. 1979. Multiple-intensity rainfall simulator for erosion research on row sideslopes. *Trans. ASAE* 22(1):100-103.
- National Oceanic and Atmospheric Administration. 1973. Western U.S. Precipitation Frequency Maps, NOAA Atlas 2. Available at <http://www.wrcc.dri.edu/pcpnfreq.html>. Accessed March 1, 2005.
- Pannkuk, C.D. and P.R. Robichaud. 2003. Effectiveness of needle cast at reducing erosion after forest fires. *Water Resources Research*. 39(12): ESG1-1 – ESG1-9.

Robichaud, P.R., J.L. Beyers, and D.G. Neary. 2000. Evaluating the effectiveness of post-fire rehabilitation treatments. General Technical Report RMRS; GTR-63. Fort Collins, CO: USDA Forest Service, Rocky Mountain Research Station.

SAS Institute Inc. 2003. SAS 9.1 TS Level 1M2. Cary, NC.



This paper was published as:

Yanosek, K.A.; Foltz, R.B.; Dooley, J.H. 2006. *Performance assessment of wood strand erosion control materials among varying slopes, soil textures, and cover amounts.* **Journal of Soil and Water Conservation** 61(2):45-51.

Moscow Forestry Sciences Laboratory
Rocky Mountain Research Station
USDA Forest Service
1221 South Main Street
Moscow, ID 83843

<http://forest.moscowfsl.wsu.edu/engr/>