

Measuring duff moisture content in the field using a portable meter sensitive to dielectric permittivity*

P. R. Robichaud^{A,G}, D. S. Gasvoda^B, R. D. Hungerford^C, J. Bilskie^D,
L. E. Ashmun^E and J. Reardon^F

^ARocky Mountain Research Station, Forestry Sciences Laboratory, U.S. Department of Agriculture Forest Service, 1221 South Main St, Moscow, ID 83843, USA.

^BRetired, Missoula Technology and Development Center, U.S. Department of Agriculture Forest Service, Missoula, MT 59808, USA.

^CRetired, Rocky Mountain Research Station, Fire Sciences Laboratory, U.S. Department of Agriculture Forest Service, Missoula, MT 59807, USA.

^DCampbell Scientific, Inc., Logan, UT 84321, USA.

^ERocky Mountain Research Station, Forestry Sciences Laboratory, U.S. Department of Agriculture Forest Service, Moscow, ID 83843, USA.

^FRocky Mountain Research Station, Fire Sciences Laboratory, U.S. Department of Agriculture Forest Service, Missoula, MT 59807, USA.

^GCorresponding author. Telephone: +1 208 883 2349; fax: +1 208 883 2318; email: probichaud@fs.fed.us

Abstract. Duff water content is an important consideration for fire managers when determining favourable timing for prescribed fire ignition. The duff consumption during burning depends largely on the duff water content at the time of ignition. A portable duff moisture meter was developed for real-time water content measurements of non-homogenous material such as forest duff. Using circuitry developed from time and frequency domain reflectometry (TDR and FDR) technologies, this sensor measures a change in frequency that is responsive to the dielectric permittivity of the duff material placed in a sample chamber and compressed. Duff samples from four forest cover types—Douglas fir, larch, lodgepole pine and spruce/alpine fir—were used to calibrate the frequency output to volumetric water content. A second-order polynomial ($R^2 = 0.97$) provides the best fit of the data to volumetric water content. The accuracy of the duff moisture meter is $\pm 1.5\%$ at 30% volumetric water content and $\pm 4\%$ at 60% volumetric water content. The volumetric water content can readily be converted to gravimetric water content, which is used more frequently by fire managers and as an input to predictive models of duff consumption.

Additional keywords: duff moisture meter; forest floor; frequency domain reflectometry (FDR); prescribed fire; time domain reflectometry (TDR).

Introduction

Prescribed burning is an effective forest resource management tool to reduce fuel build-up, remove logging debris, provide nutrients to the soil, prepare areas for planting, restore stands and create wildlife habitats (Walstad and Seidel 1990). The successful use of prescribed fire requires timely information about current fuel and moisture conditions and proper use of fire behaviour predictions to get the desired results (Walstad and Seidel 1990; Frandsen 1997). Fire and land use managers need to measure and monitor the relevant parameters that influence decisions related to prescribed burns.

The effects of forest fires are influenced by the water content of the organic material found above the mineral soil on the forest floor (Fosberg 1977; Brown *et al.* 1985; Green *et al.* 1993). This organic material commonly has three distinct layers. Litter, the top layer, is the undecomposed, unconsolidated material consisting of debris such as twigs, grasses, leaves and needles. Below the litter layer is the fermentation layer, which consists of partially decomposed organic material often bound with fungus. Humus, the third and deepest organic layer, is extensively decomposed material found between the fermentation layer and the A horizon of the mineral soil. In the field, it can be difficult to discern the

* This manuscript was written and prepared by U.S. Government employees on official time and therefore is in the public domain and not subject to copyright.

physical separation between the fermentation and humus layers because humus is usually mixed in varying proportions with partially decomposed organic materials (Green *et al.* 1993). Forest scientists and fire managers commonly use the term *duff* to refer collectively to the fermentation and humus layers, while the term *forest floor* is used to refer to all the surface organic horizons (duff and litter) overlying the mineral soil (Green *et al.* 1993; DeBano *et al.* 1998). Although there is usually a clear division between the mineral soil and overlying duff, site disturbances may mix varying amounts of mineral soil into the duff (Green *et al.* 1993).

The ground-level effects of forest fire can range from removal of litter to total consumption of the forest floor and alteration of the mineral soil structure below (Wells *et al.* 1979; Brown *et al.* 1985; Robichaud and Waldrop 1994; DeBano *et al.* 1998; Ryan 2002). Mineral soil that becomes exposed when forest floor duff is completely consumed is highly susceptible to erosion (Wells *et al.* 1979; Soto *et al.* 1994). Additionally, infiltration and water storage capacity of the mineral soil are significantly reduced because the 'sponge' effect of the organic forest floor material is gone and the mineral soil cannot absorb short-duration, high-intensity rainfall (Baker 1990). Consequently, fire managers often design prescribed fires to leave a predetermined layer of residual duff to protect the mineral soil.

Duff thickness and duff water content are the most important factors governing duff consumption during fires (Wells *et al.* 1979; Brown *et al.* 1985; McNabb and Swanson 1990; Reinhardt *et al.* 1991; Frandsen 1997). Frandsen (1997) used the water content and inorganic soil content to determine the ignition probability of a wide range of organic soils found in North America. The First Order Fire Effects Model (FOFEM) (Reinhardt and Keane 2002) uses several algorithms, over half of which are from Brown *et al.* (1985), to predict percentage duff consumption (%DR), depth (in) of duff consumed (DR), and percentage of mineral soil exposed (MSE). Twenty-one of the twenty-two model equations for duff consumption are derived from these three linear relationships:

$$\%DR = C_1 + C_2 \times \text{duff moisture} \quad (1)$$

$$DR = C_1 + C_2 \times \text{duff moisture} \\ + C_3 \times \text{preburn duff depth} \quad (2)$$

$$MSE = C_1 + C_2 \times \text{duff moisture} \quad (3)$$

where C_1 , C_2 , and C_3 are constants derived for specific habitats and geographical areas; *preburn duff depth* (in) is the thickness of the humus and fermentation layers; and *duff moisture* (%) is the gravimetric water content $[(\text{mass}_{H_2O}) / (\text{mass}_{\text{dry sample}})^{-1}(100)]$.

Although duff water content is a critical factor in the predictive models for fire behaviour, it is difficult to obtain in the field. Typically, a duff sample of known volume is taken to a laboratory to be weighed and oven-dried for 12–48 h to calculate the water content. FOFEM allows for user input

of a measured duff moisture; however, the time-consuming process of determining the duff moisture value is usually avoided. Currently, FOFEM model users can approximate the duff moisture by selecting one of four general forest moisture conditions—very dry, dry, moderate or wet—and having FOFEM assign a duff moisture value based on the 1000-h fuel moisture (Reinhardt *et al.* 1997). The FOFEM estimation of duff moisture from the 1000-h fuel moisture results in greater output variation than a measured value. In order for measured duff moisture values to be used in FOFEM, a method for obtaining immediate duff moisture content measurements, similar to that used for measuring moisture in mineral soils, was needed.

Existing electronic moisture probes, based on time domain reflectometry (TDR) technology, work well in most mineral soils. First introduced by Topp *et al.* (1980, 1982a, 1982b), TDR has developed into a widely accepted method for soil water content measurement that is rapid, non-destructive, easily automated and requires minimal soil-specific calibration (Dalton 1992; Cassel *et al.* 1994). Instruments based on TDR technology measure water content in a porous medium by determining the travel time of an electrical pulse in a transmission line, which is surrounded by the medium. Travel time is determined, in part, by the dielectric constant of the medium. The large dielectric constant of water, relative to soil minerals and air, ensures that TDR measurement can register small changes in water content, $\pm 0.006 \text{ m}^3 \text{ m}^{-3}$ (Campbell and Anderson 1998). However, conventional TDR methods are expensive and the analysis to determine travel time is complex (Campbell and Anderson 1998).

TDR soil moisture probes have been adapted for use in a range of conditions and mediums. Standard TDR soil moisture probes have been calibrated and used in a variety of soil types including organic soil (Topp *et al.* 1980), clay (Ponizovsky *et al.* 1999), and peat (Tolkka and Hallikainen 1989; Pepin *et al.* 1992). They have also been used in non-soil materials including snow (Stein and Kane 1983; Lundberg 1997), wood (Constantz and Murphy 1990), rock (Sakai *et al.* 1998; Brinley *et al.* 2002), solid waste in landfills (Li and Zeiss 2001), and oil shale waste (Reeves and Elgezawi 1992). The development of different probe configurations has enabled TDR moisture probes to be used for hard rock (Selker *et al.* 1993), soil surfaces (Inoue *et al.* 2001), and multiple depths in the soil profile (Hook *et al.* 1992; Nissen *et al.* 1999; Miyamoto *et al.* 2001).

Despite the range of adaptations, existing soil moisture probes do not work well in non-homogenous, low bulk density materials. Duff bulk density ranges from 0.3 to 0.6 g cm^{-3} and, given the nature of decaying organic material, duff is non-homogenous. Schaap *et al.* (1997) calibrated a TDR probe to measure the volumetric water content of organic forest floor that had been removed as blocks and analysed in a laboratory setting. Ferguson *et al.* (2002) used TDR probes to measure the volumetric water content of forest floor layers by placing

the probes *in situ* and calibrating each probe individually in order to compare water content between sites. However, the non-homogenous characteristics of the duff material, along with poor probe contact, make it difficult to obtain accurate water content information with any portable field instrument (Pepin *et al.* 1992).

Time and frequency domain reflectometry (TDR and FDR) technologies provided the basis for development of smaller, less expensive soil water content sensors (O'Brien and Oberbauer 2001). These sensors use a high speed line-driver configured to generate a short rise-time pulse. The travel time of the pulse in a transmission line depends on the dielectric permittivity of the material surrounding the transmission line. A reflection of the applied pulse triggers the next pulse. The time between pulses is directly related to the travel time and indirectly related to frequency, either of which can be calibrated to volumetric water content (Bilskie 1997). This circuit was adapted for use in the duff moisture meter evaluated in this study.

The objective of this study was to develop an instrument and method to obtain reliable duff water content measurements in the field. This paper describes a hand-held duff moisture meter in which the output frequency of the sensor circuit varies with the dielectric permittivity of the duff being sampled. The calibration function converts the output frequency to provide an immediate measurement of duff water content in the field.

Methods and materials

The duff moisture meter

The duff moisture meters used in these studies were the DMM600 (Campbell Scientific, Inc., Logan, UT)[†] and the two immediate precursor prototypes, the culmination of a multi-year development process (Robichaud *et al.* 1999, 2000). The two prototype duff meters included three common features of the production model: (1) a cylindrical sample chamber with interlocking finger sensor electrodes at the base; (2) a piston compression device within the sample chamber; and (3) a sensor circuit (CS615, Campbell Scientific, Inc.) modified for the duff moisture meter. Duff moisture meter models with these three features have comparable functionality and results from any such model validate the functionality of the current production model.

During early research and development efforts the CS615 circuit was adapted to function as a capacitance-sensitive oscillator when used with non-linear sensor electrodes. This circuitry became the basis for several pre-prototype duff moisture meter models that were produced and tested, eventually leading to the final shape and size of the sample chamber, sieve mesh size, sensor electrode configuration, and

sample compression system of the production model. However, all the duff moisture meters produced before 1999 varied from the production model in one or more of the three salient features described above. Hence, research and development efforts before 1999, using any of the pre-prototype models, cannot be directly correlated with the duff moisture meter evaluated in this study and are not reported here.

The duff water content measurements are derived from the frequency output of the meter's sensor circuit, and this output frequency is dependent on the dielectric properties of the material that surrounds the sensor electrodes. Duff samples contain water, air, organic material and some mineral soil in various proportions. The dielectric constant of water is normally ~ 81 , which is an order of magnitude greater than other duff constituents (air is 1; cellulose is 3–7; wood is 2–6; soil solids are 4–8) (Lide 1997; Hillel 1998). The large difference between water and all other duff constituents makes the frequency output of the duff moisture meter sensitive to water content. When the sample chamber is empty, with air acting as the dielectric surrounding the sensor electrodes, the output frequency is ~ 42 MHz. When duff material in the sample chamber surrounds the sensor electrodes, the output frequency decreases according to the water content of the duff sample. The output frequency is converted to water content using a calibration equation derived from curve-fitting laboratory and field data.

The DMM600 duff moisture meter consists of an aluminum cylindrical tube that houses the electronics, a sample chamber, and a sample chamber cap fitted with a sample compression mechanism (Fig. 1). The duff sample is sieved before measurement to remove sticks and rocks, and to provide more uniform packing. The duff is pushed by hand through a 75 mm (3 in) diameter #4 wire mesh (opening size 5.16 mm, 0.203 in) sieve (Fig. 2). After the sieved material fills the 120 cm³ (7.5 in³) chamber, the cap is attached and the compression knob is turned, moving a piston inside the sample chamber to compact the sample. Compaction reduces the amount of air within the sample. In addition, the electrical field of influence is greatest closer to the electrodes, and the compression mechanism provides better contact between the duff and the sensor electrodes at the base of the sample chamber (Robichaud *et al.* 1999). At the end of the duff meter, opposite the sample chamber, is the power switch, a two-line LCD display, and a 9-pin serial port connection.

There are two circuit boards in the duff meter (Fig. 3). Circuit I is attached under the sample chamber base plate and contains components to make the dielectric permittivity sensitive measurement. The short rise-time pulse generated on the circuit board is applied to a pair of copper-plated tin coplanar electrodes etched in an interlocking finger pattern on a Teflon circuit card (Fig. 4). Conformal coating is

[†] The use of trade or firm names in this publication is for reader information and does not imply endorsement by the U.S. Department of Agriculture of any product or service.

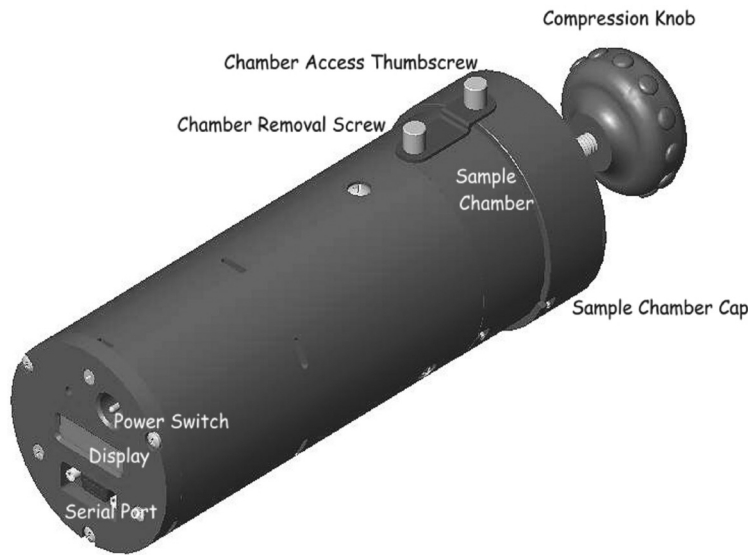

Specifications

Diameter: 9 cm (3.5 in)
 Length: 25 cm (10 in)
 Weight: 1.7 kg (3.7 lb)
 Sieve: #4 mesh = 5.16 mm (0.203 in) openings
 7.6 cm (3 in) diameter
 Battery: 9 volt alkaline
 Measurements per battery: >2000

Performance

Accuracy: 4 percent over full scale range
 Resolution: 1 percent volumetric moisture content

Fig. 1. DMM600 duff moisture meter (Campbell Scientific, Inc., Logan, UT).



Fig. 2. The duff sample is pulled from the lower duff layer and pushed by hand through the sieve directly into the sample chamber. Rocks, sticks and larger needles stay in the sieve while smaller, more decomposed pieces of duff fall into the sampling chamber.

applied to the electrodes to protect them from corrosion and aid in cleaning. The Teflon circuit card is attached to the base of the sample chamber, a low dielectric plastic plate that is supported by three compression springs. When the preset compression of 66 N (15 lb) is reached during sample compression, the water content measurement is made. An audible tone signals measurement completion, and the results are displayed on a two-line LCD display. The fixed compression ensures that each measurement is made with the same applied force to reduce measurement variability caused by inconsistent decomposition, varying amounts of mineral soil interspersed in the duff, and other differences in sample

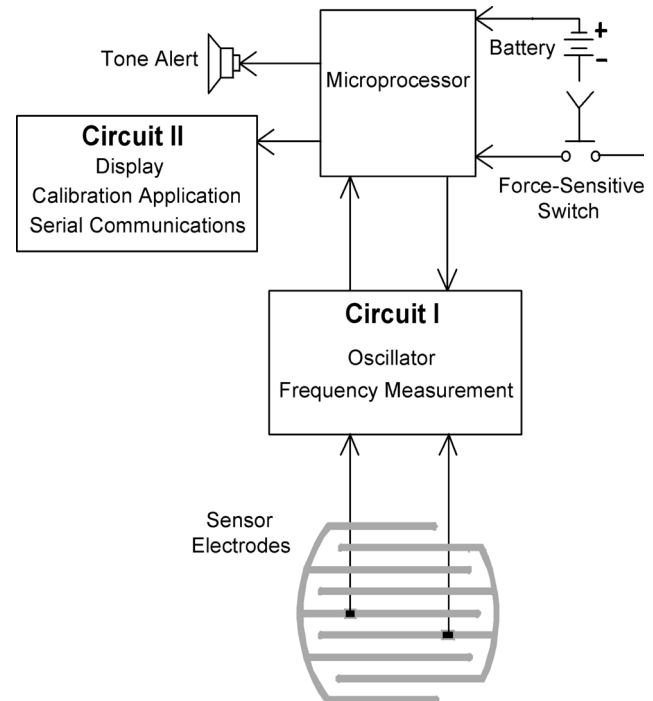

Fig. 3. Circuitry block diagram for the duff moisture meter.

consistency. Circuit II is mounted at the base of the instrument housing and drives the display, applies the calibration and controls serial communications when connected to a personal computer (Fig. 3).

Field sites and sampling

Montana field sites

Forest duff from seven sites in two western Montana drainages, Bass Creek and Nine Mile Creek on the Lolo



Fig. 4. The bottom of the sample chamber has two interlocking finger electrodes, spaced 6 mm (0.24 in) apart, etched onto a Teflon circuit card and attached to a movable plate made of low-dielectric plastic.

National Forest, were selected to include five different cover types. Bass Creek drainage had four sites that varied by dominant cover type. The cover types represented were Douglas fir (*Pseudotsuga menziesii*), western larch (*Larix occidentalis*), lodgepole pine (*Pinus contorta*), and Engelmann spruce (*Picea engelmannii*)/sub-alpine fir (*Abies lasiocarpa*). The Nine Mile Creek drainage had three sites, which included ponderosa pine (*Pinus ponderosa*), Douglas fir, and western larch cover types. These five cover types provide a range of duff materials from various elevation and moisture regimes. Five randomly selected samples within each site were taken at 2-week intervals from 10 June to 3 August 1999. Frequency readings from the duff moisture meter and sample volume at the time of measurement were determined in the field and correlated with the volumetric and gravimetric water content determined in the laboratory. The data range was limited by the low water content of the field samples during that season.

Montana field samples used for laboratory calibration

To calibrate the duff moisture meter, the range of water contents had to be extended beyond those encountered in the field trials. The four cover type duffs from Bass Creek—Douglas fir, larch, lodgepole pine and spruce/alpine fir—were analysed in the laboratory over a full range (15, 30, 40 and 60% volumetric water content) of moisture values to calibrate the duff moisture meter.

Massachusetts field samples used for validation

Eastern hardwood duff, taken from under a mixed canopy that included red oak (*Quercus rubra*), sugar maple

(*Acer saccharum*), and American beech (*Fagus grandifolia*), was collected from a relatively undisturbed forested area in the Wachusett State Forest in Massachusetts. These samples were analysed in the laboratory over the same range of water contents used for calibration.

Montana field samples used for validation

The data from the 1999 Montana field study were used to verify the applicability of the laboratory-derived calibration. In order to use these data, the frequency readings had to be adjusted because the adapted water content sensor circuits are factory-tuned to reduce variability between duff moisture meters. The standard calibration curve was developed using tuned circuit cards. However, this tuning had not been done in 1999, and the field measurements reflect a +2.07 MHz difference at oven dry, or zero% water content. Adjusting the frequency readings for this circuit card difference allowed the 1999 data to be used to verify the applicability of the duff moisture meter's standard calibration on these field readings.

Laboratory water content measurement methods

Calibration and validation of the duff moisture meter required duff material to be systematically rewetted to a range of water contents. Using standard laboratory procedures, all duff samples were oven-dried at 105°C for 12–48 h or until the sample weight did not decrease with drying time (Klute 1986). The dried duff from each cover type was divided into five samples. Water was added to four of the five samples in amounts that would result in ~15, 30, 40 and 60% volumetric water contents $[(\text{volume}_{\text{H}_2\text{O}})/(\text{volume}_{\text{sample}})]^{-1}(100)$. The fifth sample was left as oven dry to test the zero value output of the duff moisture meter. Each wet duff sample was placed in a sealed plastic bag for 8–12 h, allowing the water content to equilibrate throughout the sample. Three samples of each cover type were tested with two duff moisture meters at the four water contents as well as oven dry. The frequency readings and the volume at the time of measurement (compressed volume) were correlated with the volumetric water content as measured in the laboratory.

Calibration and validation of duff moisture meter output requires standard laboratory measurements of sample bulk density and water content. Since sample volume is needed as an input to calculate the bulk density and the volumetric water content, the DMM600 duff moisture meter sample chamber is calibrated to provide the user with a sample volume at the time of measurement when the sample is fully compressed. The sample volume (cm^3) is calculated by:

$$\text{Volume} = 157.97 - 7.25 \times \text{rotations} \quad (4)$$

where *rotations* is the number of compression knob rotations needed to reposition the compression piston from the measurement position to the maximum open position. Using

the sample volume (cm^3) before drying and the mass (g) of the sample after drying, the bulk density (BD , g cm^{-3}) of a duff sample is:

$$BD_{\text{sample}} = \frac{\text{mass}_{\text{dry sample}}}{\text{volume}_{\text{wet sample}}} \quad (5)$$

The volumetric water content (VWC) is the standard output of the duff moisture meter. The volume of water [$\text{volume}_{\text{H}_2\text{O}}$] in the sample is usually calculated from laboratory measurements using the difference in the wet sample mass (g) and the dry sample mass (g) [$\text{mass}_{\text{wet sample}} - \text{mass}_{\text{dry sample}}$] as the mass of water [$\text{mass}_{\text{H}_2\text{O}}$] in the sample. Using the density (ρ , g cm^{-3}) of water, the volume (cm^3) of water in the sample is calculated. The VWC (%) is then determined by:

$$\begin{aligned} VWC &= \frac{\text{mass}_{\text{H}_2\text{O}} / \rho_{\text{H}_2\text{O}}}{\text{volume}_{\text{wet sample}}} \times 100 \\ &= \frac{\text{volume}_{\text{H}_2\text{O}}}{\text{volume}_{\text{wet sample}}} \times 100 \end{aligned} \quad (6)$$

To determine the gravimetric water content (GWC) of a duff sample, the sample is removed from the duff meter sample chamber, weighed wet, oven-dried, and weighed dry. The GWC (%) is then determined by:

$$GWC = \left(\frac{\text{mass}_{\text{wet sample}} - \text{mass}_{\text{dry sample}}}{\text{mass}_{\text{dry sample}}} \right) \times 100 \quad (7)$$

Results and discussion

Prototype duff moisture meter

The data from the 1999 field study in Western Montana, collected in the dry summer months, contains a limited range of water contents, with most of the readings in the low moisture end (Fig. 5). VWC ranged from 1.4 to 83%, while the median values by duff type ranged from 4 to 26%. The median value across all duff types ($n = 301$) was 10% VWC . The larch cover type duff ($n = 74$) was in the middle of the range (median value of 18% VWC). However, it should be noted

that the entire dataset ($n = 301$) contained only three data points that exceeded 50% VWC , and all three were from a single site within the larch cover type.

The best-fit equations were developed for each duff type using the duff moisture meter frequency reading and the VWC and GWC (Table 1). The similarity of these best-fit second-order polynomial curves (Fig. 6a,b) was noted but, given the limited data at the higher water contents, these results did not suggest that a single calibration curve would be appropriate.

Calibration of the duff moisture meter

Four duff types were used for the laboratory measurements over a wide range of moisture contents. Calibration curves were developed by correlating the frequency readings from the duff moisture meters and the laboratory measured VWC for each of the four duff types (Fig. 7). The similarities in these four VWC calibration equations did suggest that a single calibration curve for VWC would provide adequate accuracy for most users. A single calibration curve, derived from the

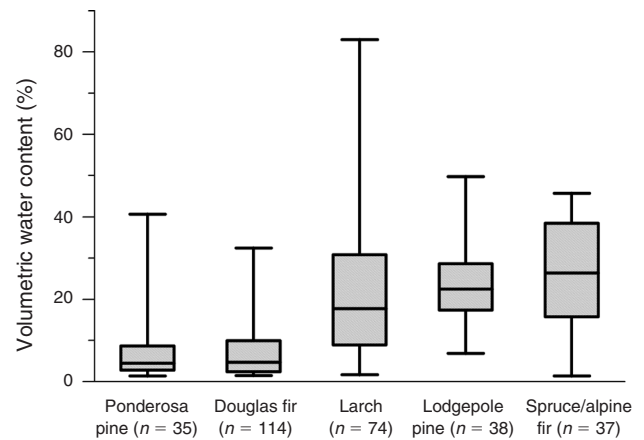

Fig. 5. This plot shows the minimum, maximum, median and quartile information for the volumetric water content of the duff samples taken from the Bass Creek/Nine Mile Creek, Montana site.

Table 1. The best-fit curves (Fig. 6a,b) for each cover type duff were developed from the relationship between the frequency readings (f) of the duff moisture meter and the volumetric water content (VWC) and the gravimetric water content (GWC) laboratory measurements

Cover type (n)	Volumetric water content equation	Gravimetric water content equation
Ponderosa pine (35)	$VWC = 59 + 4.362f - 0.127f^2$ $R^2 = 0.98$	$GWC = -313 + 40.59f - 0.754f^2$ $R^2 = 0.97$
Douglas fir (114)	$VWC = 1010 - 39.42f + 0.375f^2$ $R^2 = 0.96$	$GWC = 3280 - 126.0f + 1.179f^2$ $R^2 = 0.89$
Larch (74)	$VWC = 120 + 1.020f - 0.083f^2$ $R^2 = 0.97$	$GWC = -126 + 30.14f - 0.614f^2$ $R^2 = 0.79$
Lodgepole pine (38)	$VWC = 261 - 6.187f + 0.009f^2$ $R^2 = 0.95$	$GWC = -882 + 68.88f - 1.110f^2$ $R^2 = 0.82$
Spruce/alpine fir (37)	$VWC = 435 + 28.51f - 0.4221f^2$ $R^2 = 0.94$	$GWC = -466 + 49.38f - 0.875f^2$ $R^2 = 0.94$

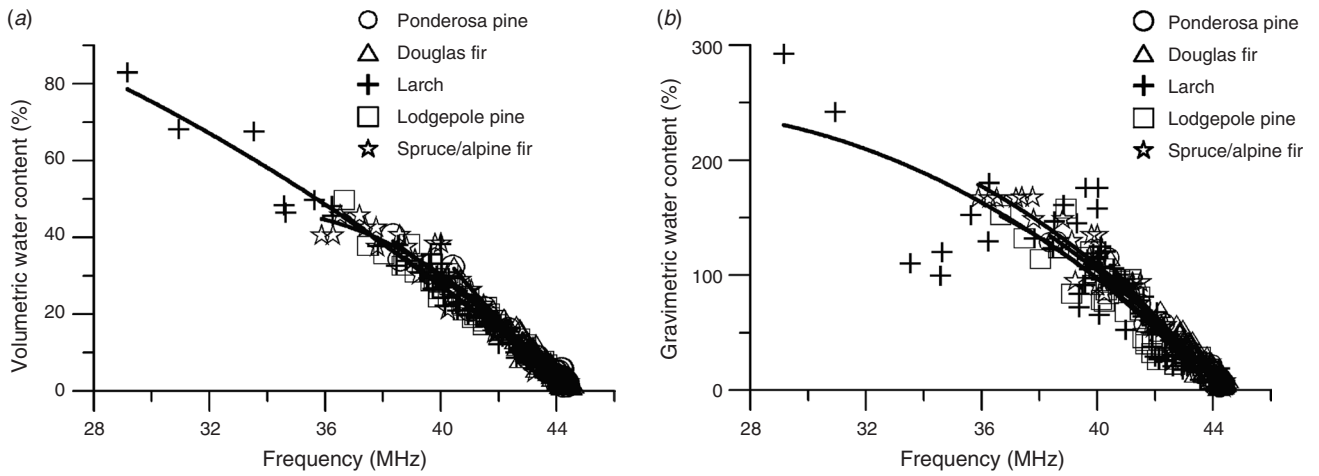

Fig. 6. The frequency readings taken at Bass Creek/Nine Mile Creek, Montana site were plotted against (a) the laboratory measured VWC and (b) the laboratory measured GWC. Best-fit curves for each cover type duff show the relationship of duff moisture meter frequency readings to VWC and GWC. The corresponding equations are listed in Table 1.

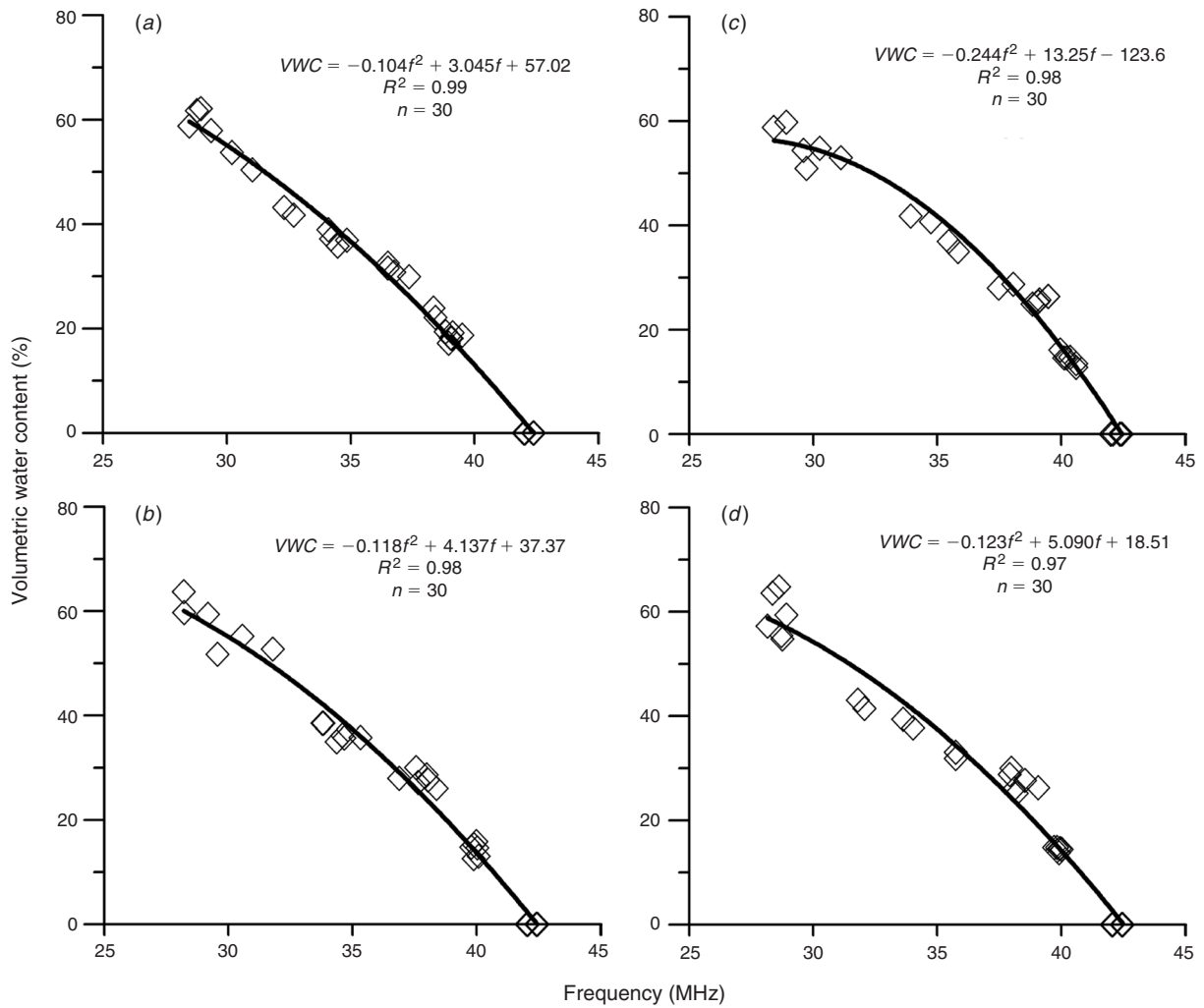

Fig. 7. The duff moisture meter VWC calibration curves were developed for four duff cover types: (a) Douglas fir, (b) larch, (c) lodgepole pine and (d) spruce/alpine fir. Six samples from each cover type at five moisture contents, including oven dry, were tested.

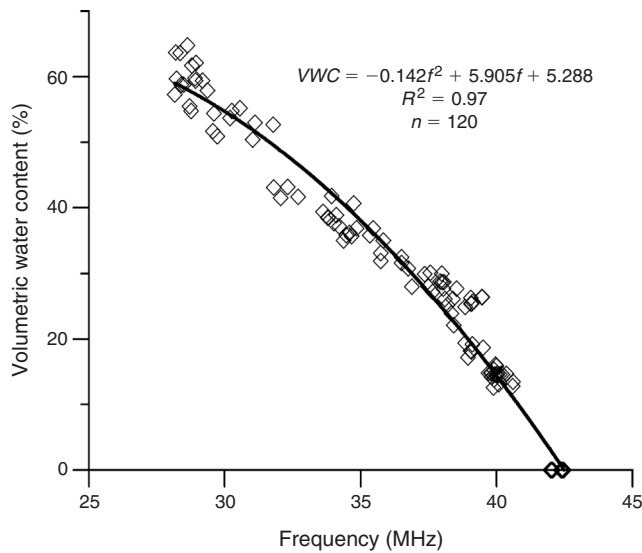

Fig. 8. The DMM600 standard calibration curve was derived from the combination of data from four duff cover types: Douglas fir, larch, lodgepole pine and spruce/alpine fir.

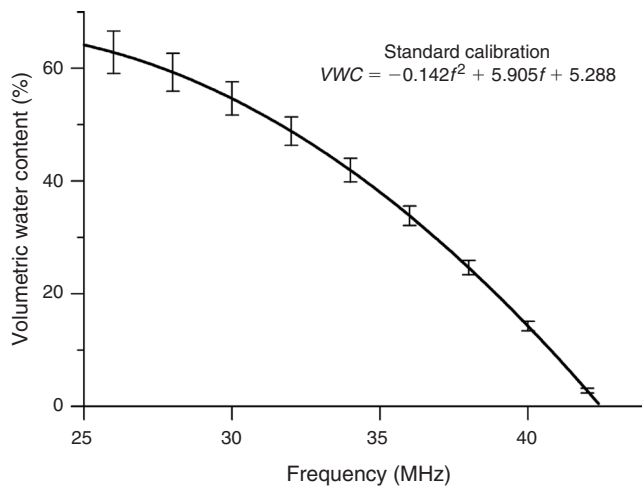

Fig. 9. The error bars on the standard calibration curve for the DMM600 duff moisture meter show that variations are smallest for lower volumetric water contents. After DMM600 Instruction Manual 2002 (Campbell Scientific, Inc. 2002).

combined data ($n = 120$) for the four duff types, is a second-order polynomial with an R^2 of 0.97 (Fig. 8). The calibration equation is:

$$VWC = 5.288 + 5.905f - 0.142f^2 \quad (8)$$

where f is the frequency reading (MHz). This equation is currently programmed into the DMM600 duff moisture meter as the ‘standard calibration’ and the VWC output is based on this standard calibration curve. The error bars on the standard calibration curve (Fig. 9) indicate that accuracy

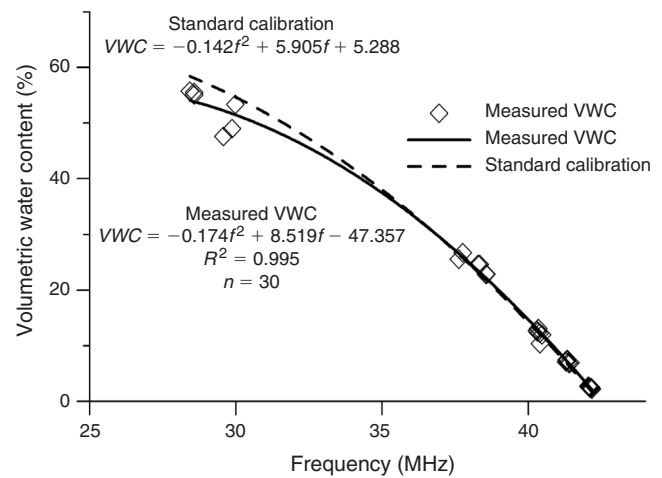

Fig. 10. Validation of the standard VWC calibration is graphically demonstrated by plotting the eastern hardwood duff moisture meter measurements with the laboratory measured VWC for the samples.

is approximately $\pm 4.0\%$ at 60% VWC and approximately $\pm 1.5\%$ at 30% VWC, which is within the accuracy range of other soil moisture meters and will likely meet the needs of most duff moisture meter users.

Range of application

Although user-defined calibrations for a specific material can be determined, our results have demonstrated that the standard calibration curve, without any adjustments, has wide applicability. The VWC of eastern hardwood duff was determined in the laboratory and compared to the VWC as measured by the duff moisture meter applying the standard calibration (Fig. 10). The average difference was 1.3% VWC over 2–55% VWC. The average difference drops to 0.65% VWC in the 0–30% VWC (~0–80% GWC) range where most prescribed burn ignition decisions are made.

The Bass Creek/Nine Mile Creek data from the summer of 1999 provide a large dataset ($n = 301$) of frequency readings and water content measurements that were used retroactively to validate the applicability of the standard calibration to field measurements. Figure 11 compares the laboratory measured VWC to the duff moisture meter VWC reading derived from the standard calibration equation. When the entire range is considered, the average difference between the measured and the calibrated VWC is 1.8%. At lower water contents, 0–30% VWC (~0–80% GWC; $n = 266$), where most prescribed burn ignition decisions are made, the average difference drops to 1.4% VWC.

Determining GWC

Volumetric water content is the standard output for the duff moisture meter. However, gravimetric water content is

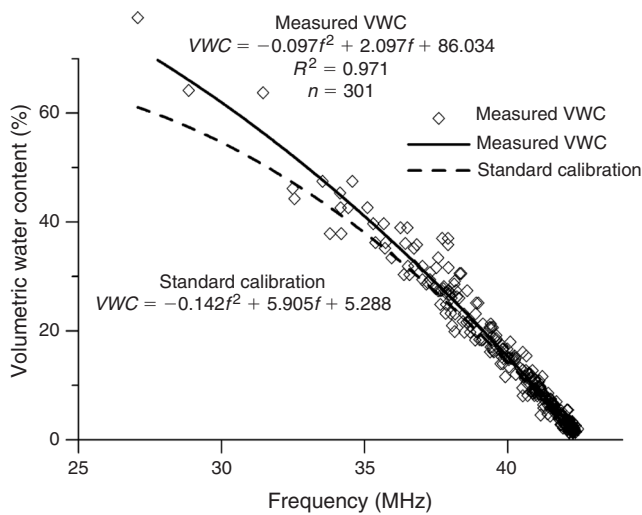

Fig. 11. Validation of the standard VWC calibration is graphically demonstrated by plotting the 1999 Bass Creek/Nine Mile Creek, Montana duff moisture meter measurements (adjusted for the factory-tuned CS615 circuit card) with the laboratory measured VWC for the samples.

commonly used in the fire community and in the duff consumption and fire behaviour models; thus it is expected to be the most commonly added user-calibration on the duff moisture meter. Making the addition of the GWC calibration easy and straightforward was an important design consideration in the development of the duff moisture meter. The VWC (equation 6) and GWC (equation 7) are related by the bulk density (BD). Consequently, if measurements are in International System (SI) units, where ρ_{H_2O} is assumed to be 1 g cm^{-3} , the relationship of VWC to GWC is:

$$VWC = GWC \times BD_{sample} \quad (9)$$

This relationship is the basis for a simplified GWC calibration method that requires no extensive laboratory testing or curve-fitting data analysis. A measured or known duff bulk density value is used to change the three standard calibration equation coefficients. The GWC coefficients are input into a PCDMM software (included with each DMM600 unit) interface window and downloaded into the duff moisture meter. Both the GWC and the VWC are automatically displayed as alternating output for each measurement.

Discussion

Post-fire ground cover is the most important site factor in determining post-fire erosion (Robichaud 2000). The difference between 20–30% ground cover and 70–80% ground cover can result in an order of magnitude difference in erosion (Robichaud and Waldrop 1994; Robichaud 2000). The duff water content before burning is the most important factor in how much duff remains after burning. Additionally, duff

water content can vary more, both temporally and spatially, than larger fuels (Robichaud and Miller 1999) making the use of generalized values less useful when trying to meet narrow prescription parameters. The duff moisture meter allows the prescription fire manager to check the duff water content before ignition to ensure that current conditions will provide the desired burn without risking unacceptable post-fire erosion rates.

The immediate moisture content readout makes the duff moisture meter a potential tool for determining where and when fire suppression efforts should be applied during wild-fires. The duff moisture meter could also be useful in field research. Within the field of forestry, the duff moisture meter could be applied in decomposition, soil respiration and mycorrhizal studies where duff water content is an important factor.

Conclusions

The duff moisture meter is a portable, electronic sensor that provides real-time water content measurements of compressible non-homogenous organic mediums such as organic forest floor material (duff). The duff moisture meter incorporates hand sieving of the sample with a hand-turned compression piston to reduce air voids and provide good contact between the medium (duff) and the electrodes. The frequency output is related through a calibration function to provide volumetric water content.

A second-order polynomial describes the relationship between frequency output and the volumetric water content. The measurement accuracy decreases as water content increases but is within $\pm 4\%$ in the 0–60% VWC range. The standard calibration has been validated for several duff types; thus, it is likely that the standard calibration curve will meet the needs of most fire managers across a range of habitat types.

The duff moisture meter is designed to assist fire managers who must make decisions about the timing of prescribed fire and in predicting wildfire behaviour. The ability to put a measured value for duff moisture into predictive fire behaviour models will enhance the output accuracy of these models. Knowing the duff moisture content allows managers to determine the probability of ignition and if current conditions are within prescription parameters.

Acknowledgements

Funding for this project has come in part from the U.S. Department of Agriculture Forest Service, Washington Office Engineering Staff, Bitterroot National Forest, Missoula Technology and Development Center, and Rocky Mountain Research Station. The Duff Moisture Meter was developed through cooperative research effort by the U.S. Department of Agriculture Forest Service Rocky Mountain Research

Station and Missoula Technology and Development Center. The Forest Service collaborated with Campbell Scientific, Inc., Logan, UT for production and marketing.

References

- Baker MB, Jr (1990) Hydrologic and water quality effects of fire. In 'Proceedings: effects of fire management of Southwestern natural resources'. (Tech. Ed. JS Krammes) USDA Forest Service, Rocky Mountain Research Station General Technical Report RM-191. (Ft Collins, CO)
- Bilskie J (1997) Using dielectric properties to measure soil water content. *Sensors* **14**, 26–34.
- Brinley A, Winship P, West JL, Pokar M, Middleton R (2002) Seasonal variation of moisture content in unsaturated sandstone inferred from borehole radar and resistivity profiles. *Journal of Hydrology* **267**, 160–172. doi:10.1016/S0022-1694(02)00147-6
- Brown JK, Marsden MA, Ryan KC, Reinhardt ED (1985) 'Predicting duff and woody fuel consumed by prescribed fire in the northern Rocky Mountains.' USDA Forest Service, Intermountain Research Station Research Paper INT-337. (Ogden, UT)
- Campbell GS, Anderson RY (1998) Evaluation of simple transmission line oscillators for soil moisture measurement. *Computers and Electronics in Agriculture* **20**, 31–44.
- Campbell Scientific, Inc. (2002) 'DMM600 instruction manual.' (Campbell Scientific, Inc., Logan, UT)
- Cassel DK, Kachanoski RG, Topp GC (1994) Practical considerations for using a TDR cable tester. *Soil Technology* **7**, 113–126. doi:10.1016/0933-3630(94)90013-2
- Constantz J, Murphy F (1990) Monitoring moisture storage in trees using time domain reflectometry. *Journal of Hydrology* **119**, 31–42. doi:10.1016/0022-1694(90)90032-S
- Dalton FN (1992) Development of time-domain reflectometry for measuring soil water content and bulk soil electrical conductivity. In 'Advances in measurement of soil physical properties: bringing theory into practice'. (Eds GC Topp, WD Reynolds) pp. 143–167. Special Publication No. 30. (Soil Science Society of America: Madison, WI)
- DeBano LF, Neary DG, Ffolliott PF (1998) 'Fire's effects on ecosystems.' (John Wiley & Sons: New York)
- Ferguson SA, Ruthford JE, McKay SJ, Wright D, Wright C, Ottmar R (2002) Measuring moisture dynamics to predict fire severity in longleaf pine forests. *International Journal of Wildland Fire* **11**, 267–279. doi:10.1071/WF02010
- Fosberg MA (1977) 'Heat and water transport properties in conifer duff and humus.' USDA Forest Service, Rocky Mountain Forest and Range Experiment Station Research Paper RM-195. (Ft Collins, CO)
- Frandsen WH (1997) Ignition probability of organic soils. *Canadian Journal of Forest Resources* **27**, 1471–1477. doi:10.1139/CJFR-27-9-1471
- Green RN, Trowbridge RL, Klinka K (1993) 'Towards a taxonomic classification of humus forms.' Forest Science Monograph No. 29. (Society of American Foresters: Washington, DC)
- Hillel D (1998) 'Environmental soil physics.' (Harcourt Brace/Academic Press: San Diego)
- Hook WR, Livingston NJ, Sun ZJ, Hook PB (1992) Remote diode shorting improves measurement of soil water by time domain reflectometry. *Soil Science Society of America Journal* **56**, 1384–1391.
- Inoue Y, Watanabe T, Kitamura K (2001) Prototype time-domain reflectometry probes for measurement of moisture content near the soil surface for applications to 'on-the-move' measurements. *Agricultural Water Management* **50**, 41–52. doi:10.1016/S0378-3774(01)00091-9
- Klute A (Ed.) (1986) 'Methods of soil analysis: part 1, physical and mineralogical methods. Agronomy series, No. 9.' 2nd edn. (American Society of Agronomy and Soil Science Society of America: Madison, WI)
- Li RS, Zeiss C (2001) *In situ* moisture content measurement in MSW landfills with TDR. *Environmental Engineering Science* **18**, 53–66. doi:10.1089/109287500750070252
- Lide DR (Ed.) (1997) 'CRC handbook of chemistry and physics.' 78th edn. (CRC Press: Cleveland, OH)
- Lundberg A (1997) Laboratory calibration of TDR-probes for snow wetness measurements. *Cold Regions Science and Technology* **25**, 197–205. doi:10.1016/S0165-232X(96)00012-2
- McNabb DH, Swanson FJ (1990) Effects of fire on soil erosion. In 'Natural and prescribed fire in Pacific Northwest forest'. (Eds JD Walstad, SR Radosovich, DV Sandberg) pp. 159–176. (Oregon State University Press: Corvallis)
- Miyamoto T, Kobayashi R, Annaka T, Chikushi J (2001) Applicability of multiple length TDR probes to measure water distributions in an Andisol under different tillage systems in Japan. *Soil and Tillage Research* **60**, 91–99. doi:10.1016/S0167-1987(01)00172-6
- Nissen HH, Moldrup P, de Jonge LW, Jacobsen OH (1999) Time domain reflectometry coil probe measurements of water content during fingered flow. *Soil Science Society of America Journal* **63**, 493–500.
- O'Brien JJ, Oberbauer SF (2001) An inexpensive, portable meter for measuring soil moisture. *Soil Science Society of America Journal* **65**, 1081–1083.
- Pepin S, Plamondon AP, Stein J (1992) Peat water content measurement using time domain reflectometry. *Canadian Journal of Forest Research* **22**, 534–540.
- Ponizovsky AA, Chudinova SM, Pachepsky YA (1999) Performance of TDR calibration models as affected by soil texture. *Journal of Hydrology* **218**, 35–43. doi:10.1016/S0022-1694(99)00017-7
- Reinhardt ED, Keane RE (2002) 'FOFEM Version 5.0. First Order Fire Effects Model.' USDA Forest Service, Intermountain Fire Sciences Laboratory, Rocky Mountain Research Station. (Missoula, MT) Available at <http://fire.org> [Verified 13 September 2004]
- Reinhardt EG, Keane RE, Brown JK (1997) 'First order fire effects model: FOFEM 4.0, user's guide.' USDA Forest Service, Intermountain Research Station General Technical Report INT-GTR-344. (Ogden, UT)
- Reinhardt EG, Brown JK, Filcher WA, Graham RT (1991) 'Woody fuel and duff consumption by prescribed fire in the northern Idaho mixed conifer logging slash.' USDA Forest Service, Intermountain Research Station Research Paper INT-443. (Ogden, UT)
- Reeves TL, Elgezawi SM (1992) Time domain reflectometry for measuring volumetric water content in process oil shale waste. *Water Resources Research* **28**, 769–776. doi:10.1029/91WR02895
- Robichaud PR, Waldrop TA (1994) A comparison of surface runoff and sediment yields from a low- and high-severity site preparation burns. *Water Resources Bulletin* **30**, 27–34.
- Robichaud PR, Miller SM (1999) Spatial interpolation and simulation of post-burn duff thickness after prescribed fire. *International Journal of Wildland Fire* **9**, 137–143. doi:10.1071/WF00018
- Robichaud PR, Hungerford RD, Gasvoda DS (Inventors), The United States of America as represented by the Secretary of Agriculture, assignee (1999) Apparatus and Method for the Measurement of Forest Duff Moisture Content. U.S. patent 5,920,195. July 6. pp. 11 Int. Cl⁶G01R 27/26.
- Robichaud PR, Hungerford RD, Gasvoda DS (Inventors), The United States of America as represented by the Secretary of Agriculture, assignee (2000) Method for the Measurement of Forest Duff Moisture Content. U.S. patent 6,078,181. June 20. pp. 10 Int. Cl⁷G01R 27/26.

- Robichaud PR (2000) Fire effects on infiltration rates after prescribed fire in northern Rocky Mountain forests, USA. *Journal of Hydrology* **231–232**, 220–229. doi:10.1016/S0022-1694(00)00196-7
- Ryan KC (2002) Dynamic interactions between forest structure and fire behavior in boreal ecosystems. *Silva Fennica* **36**, 13–39.
- Sakai T, Suihara K, Adachi T (1998) Application of time domain reflectometry to the determination of volumetric water content in rock. *Water Resources Research* **34**, 2623–2631. doi:10.1029/98WR02038
- Schaap MG, de Lange L, Heimovaara TJ (1997) TDR calibration of organic forest floor media. *Soil Technology* **11**, 205–217. doi:10.1016/S0933-3630(96)00128-6
- Selker JS, Graff L, Steenhuis T (1993) Noninvasive time domain reflectometry moisture measurement probe. *Soil Science Society of America Journal* **57**, 934–936.
- Soto B, Basanta R, Benito E, Perez R, Diaz-Fierros F (1994) Runoff and erosion from burnt soils in northwest Spain. In 'Proceedings: Soil erosion and degradation as a consequence of forest fires. 1991'. (Eds M Sala, JL Rubio) pp. 91–98. (Barcelona, Spain)
- Stein J, Kane DL (1983) Monitoring the unfrozen water content of soil and snow using time domain reflectometry. *Water Resources Research* **19**, 1573–1584.
- Tolkka MV, Hallikainen M (1989) A practical electric instrument for *in situ* measurement of peat properties. In 'Proceedings of the 11th international congress on agricultural engineering'. (Eds VA Dodd, PM Grace) pp. 101–105. (Dublin ICAE: Rotterdam)
- Topp GC, Davis JL, Annan AP (1980) Electromagnetic determination of soil water content: measurements in coaxial transmission lines. *Water Resources Research* **16**, 574–582.
- Topp GC, Davis JL, Annan AP (1982a) Electromagnetic determination of soil water content using TDR: I. Applications to wetting fronts and steep gradients. *Soil Science Society of America Journal* **46**, 672–678.
- Topp GC, Davis JL, Annan AP (1982b) Electromagnetic determination of soil water content using TDR: II. Evaluation of installation and configuration of parallel transmission lines. *Soil Science Society of America Journal* **46**, 678–684.
- Walstad JD, Seidel KW (1990) Use and benefits of prescribed fire in reforestation. In 'Natural and prescribed fire in Pacific Northwest forest'. (Eds JD Walstad, SR Radosevich, DV Sandberg) pp. 67–79. (Oregon State University Press: Corvallis)
- Wells CG, Campbell RE, DeBano LF, Lewis CE, Fredriksen RL, Franklin ED, Froelich RC, Dunn PH (1979) 'Effects of fire on soil: a state-of-knowledge review.' USDA Forest Service, General Technical Report WO-7. (Washington, DC)